



ET16

Tracked Conventional Excavator

Best in class in terms of cabin size

In addition to its comfortable cabin, the ET16 also impresses with a compact and sturdy design. With a shipping weight of less than 1.6 metric tons, it can be quickly and easily transported from one construction site to the next. It is the ideal companion for any application due to the simple and safe operation. With the load-sensing hydraulic system (LUDV), the joystick movements always remain the same for the operator so that he can work comfortably and fatigue-free.

Highlights

- Powerful drive system with LUDV
- Hydraulic telescopic travel gear with dozer blade extension
- Large ergonomic comfort cab
- Easy transport with a car trailer
- Hydraulic joystick operation

Technical Data

Hydraulic

operating pressure	200,0 bar
hydraulikpump	ZRP
flow rate	33,0 l/min
flow rate max.	35,0 l/min
tank capacity	20,0 l

Mechanical - Output Details

Gradeability	27,0 %
Travel speed	4,1 km/h

Mechanical Details

Length	3.644,0 mm
Width	990,0 mm
Height	2.285,0 mm
Aggr. pwr time limited 1~(LTP)	1.529,0 - 1.842,0 kg
Digging depth (max.)	2.413,0 mm

Engine

Cooling	water-cooling
---------	---------------

Engine type	Diesel engine
Cylinder	3,0
Cylinder capacity	1.116,0 cm3
Effective power	13,8 KW
Nominal Engine speed	2.200,0 1/min
Exhaust-gas limit	EU Stage V
Battery capacity (nom. value)	44,0 Ah
Manufacturer	Yanmar
Engine designation	3TNV76

Environment Data

Sound level LpA	79,0 dB(A)
Sound power LWA, guaranteed	93,0 dB(A)

Chassis

operating pressure	200,0 bar
--------------------	-----------

Shipping and Storage

Shipping weight	1.402,0 kg
-----------------	------------

Dimensions

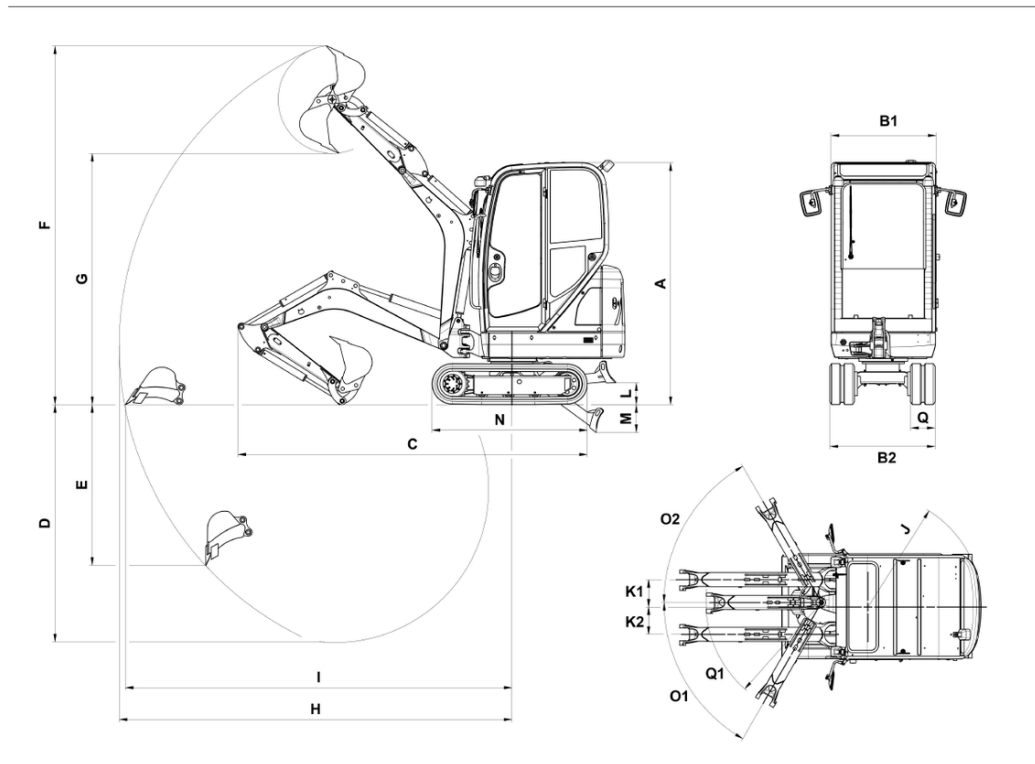

A	Height of canopy	2,285 mm
	Height of dozer blade	211 mm
B1	Width of upper carriage	990 mm
B2	Width travel gear	990 mm
C	Transport length short shovel arm	3,644 mm
	Transport length long shovel arm	3,607 mm
D	Digging depth max., short shovel arm	2,242 mm
	Digging depth max., long shovel arm	2,413 mm
E	Piercing depth max., short shovel arm	1,642 mm
	Piercing depth max., long shovel arm	1,802 mm
F	Piercing height max., short shovel arm	3,387 mm
	Piercing height max., long shovel arm	3,508 mm
G	Dumping height max., short shovel arm	2,371 mm
	Dumping height max., long shovel arm	2,493 mm
H	Digging radius max., short shovel arm	3,700 mm
	Digging radius max., long shovel arm	3,861 mm
I	Max. reach at ground level (short shovel arm)	3,648 mm
	Max. reach at ground level (long shovel arm)	3,811 mm
J	Tail swing radius	1,075 mm
K1	Boom offset max. (to center of bucket right side)	432 mm
K2	Boom offset max. (to center of bucket left side)	287 mm
L	Stacking height max. (dozer blade above surface)	211 mm
M	Digging depth max. (dozer blade below surface)	264 mm
N	Length travel drive	1,462 mm
O1	Max. swivel angle (arm system to the left)	73 °
O2	Max. swivel angle (arm system to the right)	49 °
	Track width	230 mm
Q1	Boom swing radius left	1,195 °
	Distance bucket dozer blade, short shovel arm	452 mm
	Distance bucket dozer blade, long shovel arm	385 mm